

# Audio Research SP-3, A, & A1 Modification Instructions

## I. Introduction

This document describes a series of modifications for the Audio Research SP-3 preamplifier series that address the phono amplifier, line amplifier, and high voltage power supply. Once completed significant sonic improvements will be gained. Specifically, the bass frequencies will be much more defined and extended compared to the stock SP-3 series whose weak and loose bass response was one of its major limitations. The musical character of the midrange will be retained while resolution, dynamics, and imaging will be dramatically improved. These attributes extend to the highest frequencies that were formerly veiled and un-involving providing a new sense of presence and clarity. These improvements successfully met the goal of extending the positive attributes of the original across the entire frequency spectrum and improving imaging and dynamic contrasts without adding any negative artifacts. The result is an accurate and musical recreation of the original performance in its original space that totally involves the listener without introducing any listening fatigue. Several of the changes described were eventually introduced in future preamplifiers released by Audio Research most specifically in the SP-8.

Beginning with the ARC SP-3 phono stage, the RIAA equalization components will be replaced to correct the severe inaccuracy in the original design. The resultant values will return the RIAA equalization to within 0.5% of the standard. The phono stage cathode follower is responsible for serious veiling and therefore will be removed. There are no consequences to the removal of the phono cathode follower except when a continuous load (such as a tape recorder input) is connected to the “Tape Out” connectors. In addition, selected component changes will be made to the audio circuitry to improve input overload margin and linearity.

Next the ARC SP-3 line amplifier will be addressed improving its linearity, noise level, and output impedance performance. The original ARC SP-3 line amplifier was overly complex – as ARC introduced later revisions and finally introduced new preamplifiers (specifically the SP-6 & SP-8), the line amplifier lost its complexity. Later designs were not only simpler but were audibly much better. The changes described in this document are philosophically in alignment with this evolution and will result in a simpler and higher performance line amplifier. Many components will be removed and some will be changed to improve both measurable and audible performance.

As ARC continued to upgrade the SP-3 series, the most significant changes were made to the power supply. Unfortunately it was not until the release of the SP-6, SP-8, and SP-10 did ARC deliver a truly neutral and sonically inert power supply. We will describe the steps necessary to build and install a power supply regulator assembly that contains both a pre regulator and four independent high speed wide bandwidth servo regulators. These regulators will not only significantly improve the power supply but will better the



# Audio Research SP-3, A, & A1 Modification Instructions

performance of the power supply currently delivered with ARC preamps. The result will be a dramatic increase in the bass and dynamics of the preamplifier.

You may apply the modification to any or all of the three sections described – the phono amplifier, line amplifier, and high voltage power supply. They are independent however each is contributory to the final result.

Additional documents referenced (and available from our web page) are:

- a. General Overview Assembly Notes (CAE Tech Note # 1)
- b. Soldering Tutorial (CAE Tech Note # 2)
- c. Recommended Tools & Test Instruments (CAE Tech Note # 3)

Please take the time to familiarize yourself with all of these documents in particular Tech Note # 1.

## II. General Overview

Take time to review all of the documentation provided including the aforementioned tech notes related to soldering technique and proper tools and test equipment. Each section of the SP-3 (phono, line, and power supply) is discussed separately. We have performed this modification to several hundred units and we have used our notes and experience to prepare this document. The steps follow our procedure when performed internally. Please follow the same sequence to maximize efficiency and eliminate errors. It is also very helpful to read each section before beginning to gain a visual idea of the construction.

There were at least three (but maybe more) versions of the SP-3 including the “A” & “A1” versions. We have not included a copy of the original AR schematic but refer you to your owner’s manual – you will find that our diagrams and descriptions refer to the original ARC designations (e.g. R1, R2, C1, C2). We have prepared a series of “generic” schematics to guide your work.

I suggest construction in the sequence: line amplifier, power supply, phono stage. In this way you can check your progress and audition the results incrementally.

When completed, the original specifications will be improved with reduced THD & IM distortion and lower noise floor

Although you are unlikely to encounter any problems, should they occur they would almost certainly be based on incorrect component replacement or questionable soldering connections. Therefore to avoid the time consuming and frustrating task of troubleshooting afterwards please remember these simple suggestions:

# Audio Research SP-3, A, & A1 Modification Instructions

- a. **Proper soldering is crucial.** Please refer to our soldering tutorial and practice on surplus boards until you master the technique. Be especially careful to avoid solder bridges or “cold” solder joints. Our experience shows that nearly **95% of all problems are associated with soldering related errors.**
- b. Diodes, transistors, IC’s, (all semiconductors) and many capacitors (always electrolytic types) are polar - this means that **there is a right and wrong way to insert polarized components in the board.** If placed backwards, the component and probably others nearby will be damaged upon initial power application. Double check each step associated with these parts and once again later after you have had a chance to take a break.
- c. Some components are color coded with their value (mostly resistors, but there may be others). If you are not proficient at reading these codes, use an ohmmeter to double check the value of each resistor before insertion. It is very easy to confuse a 100 ohm metal film resistor with a 1000 ohm resistor or worse with a 100K ohm resistor.

### III. Internal Wiring

Before you begin, make sure that your preamp has been off for a few hours. The ARC preamps employ significant power supply capacitance that may hold its charge for a time period much longer than normal preamps.

Begin by removing the top cover of your SP-3. It is held in place with four 1/8” hex sheet metal screws on the top and three each on each side.

Next remove the bottom cover – it is a screen that once removed will provide partial access to the two main PC boards. Note that the bottom screen is also held with the four feet – they must be removed as well.

Unless otherwise specified, **you should use 20 to 22 gauge stranded wire with Teflon insulation.** Thicker wire, solid wire, or PVC insulation will cause problems - if not now (too much strain on the boards or parts) or later (reliability issues). We can’t overemphasize this issue.

### III. Line Amplifier Modification

Components are to be inserted on the non foil side and soldered on the foil side. The sequence of assembly has been chosen so that the components with the lowest profile (such as jumpers, low power resistors, IC's etc.) are installed first with higher profile components added until the highest profile components are installed last.

Refer to both our generic SP-3 schematic diagram and the schematic diagram that is found in your owner's manual. We have provided two line amplifiers diagrams depending upon if you have an original SP-3 / SP-3A or an SP-3A1 – please refer to the correct diagram. Be sure to observe correct orientation of polar components (capacitors and diodes). Be sure also to check with an ohmmeter resistor values if you are not absolutely sure of how to read metal film resistor color codes. Note that the part designations are the same for both channels therefore you will be required to identify each part designated twice – once for each channel. We will describe how to locate the part targeted.

1. Remove C12 (5pF Silver Mica). Remember, there are two – one for each channel. The first will be connected to V4, pins 1 & 2. The second will be connected to V4, pins 6 & 7. V4 is the third tube (of five) beginning from the left (looking from the front of the preamp) that parallel the front to the preamp. You can determine the pin number by counting clockwise from the bottom of the tube (foil side of the board) starting at the gap.
2. Remove C13 (39pF Silver Mica). There are two – one for each channel. The first will be connected to V4, pins 2 & 3. The second will be connected to V4, pins 7 & 8.
3. These steps are for SP-3 and SP-3A series (not SP-3A1 or later).

Locate R20. You can find R20 by first locating pin 3 of V4 – connected to pin 3 will be R21 (2.2K). On the other side of R21 you will find R20 and also R24 (or R67 in later preamps). On the other side of R20 will be C10 (or C38 in later preamps).

First – short out C10 (or C38 in later preamps). You can either replace the capacitor with a short or simply run a shorting wire from one end to the other of the capacitor.

Second, remove R20.

Third, replace R24 (R67 in later preamps) with a 4.99K, 1/2W, Metal Film Resistor.

Now repeat the steps for the other channel. You can find the other R20 by first locating pin 8 of V4. Once again connected to pin 8 will be the other R21 (2.2K). On the other side of the other R21 will be the other R20 and also the other R24 (R67 in later preamps). Finally on the other side of R20 will be the other C10. (or C38 in later preamps).

# Audio Research SP-3, A, & A1 Modification Instructions

4. Locate R44 (75 ohm, 5Watt) and remove. It will be connected to printed circuit board terminals 32 & 34. Most versions of the SP-3 used resistors that were royal blue in color with a glass finish to the surface of the resistor. There are several of these on the pc board, make sure that you have located the resistor connected to terminals 32 & 34.
5. Locate R45 (75 ohm, 5Watt) and remove. It will be connected to printed circuit board terminals 30 & 31. Again, this resistor most likely is royal blue with a glassy finish.
6. Locate the “Contour” Control on the front panel. There will be a wire (probably green) connected from one end of the Contour Control to C18 (C39 in later preamps). Cut this wire at both ends and remove. Remember to do the same for the other channel.
7. Locate R28 (R68 in later preamps). R28 should be connected to V4 pin 3. Remove it. The other R28 should be connected to pin 8 of V4. Remove it also.
8. Locate C15 (C47 in later preamps). C15 should be connected to V4 pin 3. Remove it. The other C15 should be connected to pin 8 of V4. Remove it also.
9. Locate C18 (C39 in later preamps). You can find C18 by first locating pin 3 of V6 – connected to pin 3 will be C17 (1uF / 400VDC). On the other side of C17 you will find C18 (or C39 in later preamps).

Short out C18 (or C39 in later preamps). You can either replace the capacitor with a short or simply run a shorting wire from one end to the other of the capacitor. Replace C17 with a 0.47uF / 400 high quality polypropylene capacitor (WIMA suggested).

Locate the other C18 by first locating pin 8 of V6 and then following the steps above short it out. Replace the remaining C17 with a high quality polypropylene.

10. Replace C14 with a high quality polypropylene capacitor of the same rating (0.1uF / 400VDC). You can locate C14 by first identifying pin 1 (and pin 6 on the other channel) of V4. C14 is connected to this point.

11 Remove V7 & V8 (removes the tone control circuit).

12. Visually inspect all of your solder connections. Refer to the adjacent diagram.

Quality solder connections should be smooth and shiny. Dull surface or large blobs on the PC board should be cleaned and resoldered. In this case remove the old solder with solder wick or similar and resolder the connection.

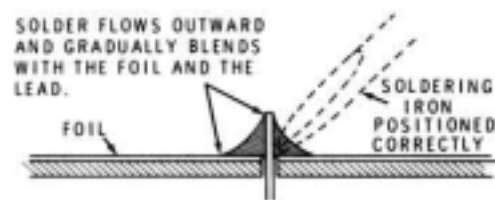

# Audio Research SP-3, A, & A1 Modification Instructions

## IV. Power Supply Modification (QPSA-7)

The modification of the power supply will require the construction and installation of CAE Quad Servo Regulator module (QPSA-7A). In this section we will describe the steps to construct and install this module.

### A. Building the Quad Servo Regulator PC Board (QPSA-7A)

Components are to be inserted on the non foil side and soldered on the foil side. The sequence of assembly has been chosen so that the components with the lowest profile (such as jumpers, low power resistors, IC's etc.) are installed first with higher profile components added until the highest profile components are installed last.

Refer to the component placement drawing (figure 1). Be sure to observe correct orientation of polar components (Capacitors, Diodes, Signal & Power Transistors, and IC's). Be sure also to check with an ohmmeter resistor values if you are not absolutely sure of how to read resistor color codes.

1. Refer to Figure 1 (Top View PC Board Component Placement Diagram). Begin by installing all of the ½ Watt resistors. There are a total of five (6) ½ Watt resistors specified (R1, R2, R3, R5, R6 & R7). The board has been designed so that a gentle radius near the body of the resistor will position the leads in alignment with the associated holes in the PC Board. Note that the ½ Watt resistors should be inserted so that the body of the resistor rests gently against the PC Board. After inserting the resistor leads thru the board, a slight bending outward of the leads will hold the part in place until you can solder it in place.

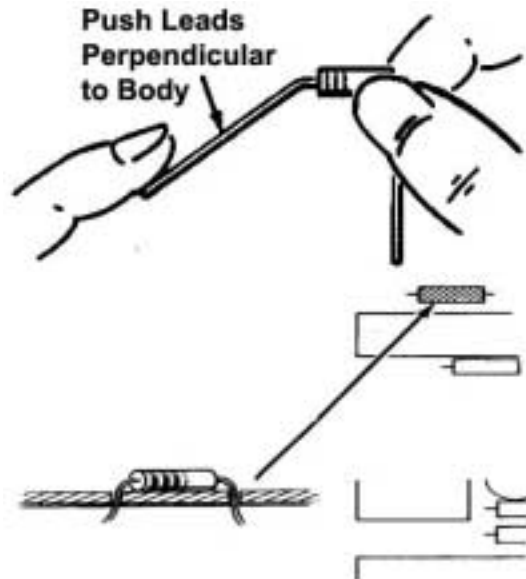

2. Install the ¼ Watt resistors. There are (7) seven: R9, R10, R11, R12, R13, R14, & R15.
3. Install the jumper located between R14 & R15.
4. Install the five (5) rectifier diodes (D1 thru D5). Please note the correct polarity.
5. Install the two Zener Diodes (DZ1 a 6.2V Zener diode and DZ2 a 30V Zener diode. Please note the correct polarity.
6. Install the two (2) operational amplifiers IC's (IC2 & IC3). Please note the polarity is indicated by either a square slot on one side of the chip or a small circular notch near pin 1 this circle also identifies the same side as the square notch.
7. Install IC1 (LM317T). Note that it does not use a heatsink.

## Audio Research SP-3, A, & A1 Modification Instructions

8. Install Q2 (TIP-50) power transistor and heatsink. Locate the TIP-50 power transistor and place it so that its mounting hole aligns with the mounting hole in the PC board. Note the position of the leads relative to the three holes in the board and using a small pair of needle nose pliers, bend the leads at right angle to the transistor body so that the transistor when mounted to the PC board has its three leads aligned with the associated holes. Place the three leads of the transistor loosely into their respective holes. Mount the transistor to the board via a composite of items as follows: 6-32 X 3/4" screw, transistor (front), heatsink compound, heatsink, PC Board (component side) star lock washer (on foil side), 6-32 nut (on foil side). Position the heatsink so that it is nearly parallel to the top of the board. To achieve a solid thermal connection between the power transistor and the heatsink please be certain to use heat sink compound liberally between the two devices. It is not necessary to insulate the transistor from the heatsink.
9. Install Q1 (MPS-A42) small signal transistor. Note that the MPS-A42 is packaged in exactly the same package as the four other small signal transistors (2N4400 / 2N4401). Be sure you have the correct device and note that the "flat" of the transistor should point to the larger Q2 (TIP-50) transistor.
10. Install the four remaining small signal transistors (Q3, Q4, Q5, & Q6 all 2N4400 / 2N4401 transistors). Be sure you have the correct device and note that the "flat" of the transistors should point away from the heatsink and Q2 (TIP-50) transistor.
11. Install the two 3 Watt metal Oxide resistors (R4 & R8). You should also gently bend the leads of this resistor similar to the 1/2 Watt resistors (but of course with a greater radius). But unlike the 1/2 Watt resistors, the # Watt Resistors should be spaced away from the plane of the PC Board by 1/16" to allow for heat dissipation.
12. Install the single film capacitor C2.
13. Install the single electrolytic capacitors (C1). Please note the orientation as these are polar (there is a correct orientation indicated by the (+). The positive lead should be inserted into this hole.
14. You will now install the two right angle mounting brackets. Please note that in order for the mounting holes to align with existing holes in the PAS chassis it will be necessary to install each in a certain direction and plane.

Assemble a composite of items as follows: 6-32 X 1/4" Screw, PC Board (Foil Side), angle bracket (pointing to the Component Side, 6-32 Nut. Do not use a screw longer than 1/4" (for clearance purposes). Tighten the assembly and orient the bracket so that it is perpendicular to the PC Module. Repeat for the other bracket. o that it is perpendicular to the PC Module

# Audio Research SP-3, A, & A1 Modification Instructions

15. Visually inspect all of your solder connections. Refer to the adjacent diagram. Quality solder connections should be smooth and shiny. Dull surface or large blobs on the PC board should be cleaned and resoldered. In this case remove the old solder with solder wick or similar and resolder the connection.

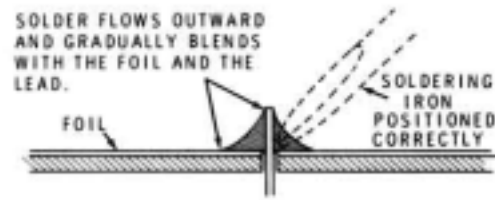

## B. Installing the QPSA-7A Servo Regulator Module

The QPSA-7A module fabricated in the previous section will now be installed and connected to your SP-3. You can visualize the installation of the QPSA-7A module as an insertion into the SP-3 between the current power supply and the phono and line amplifier circuitry. To accomplish this “insertion” it will be necessary to only disconnect the audio amplification circuitry from the SP-3 power supply and place the QPSA-7A such that the input to the QPSA-7A is fed from the SP-3 power supply and the output of the QPSA-7A feeds the audio amplification circuitry power leads. To accomplish this it will be necessary to remove leads and perhaps cut foil on the SP-3 pc board.

The QPSA-7A contains four independent regulators (Vo1 thru Vo4). These outputs will connect to the four main B+ lines in the SP-3: B+2, B+3, B+4 & B+5 that supply power to the phono and line amplifier circuits. (We will not use B+1 – it was originally used to supply the Tone Control section which we have previously removed.)

Note - It will also be necessary to include a small value electrolytic capacitor near the circuitry being regulated – that’s is at the point where the QPSA-7A power output leads connect to the SP-3 circuit board right at the SP-3 PC terminals. With four independent regulators, four capacitors will be required. The capacitor specified is 10uF @ 450VDC. This is a very small capacitor that should be easy to install either in the component or foil side of the board.

In all versions of the SP-3, ARC maintained the same terminal number association with the B+ lines supplying power to the audio circuitry. The regulated outputs from QPSA-7A will connect to these terminals. For your reference these associations are:

- B+2 = PC Terminal # 17 = Connected to Vo4
- B+3 = PC Terminal # 20 = Connected to Vo3
- B+4 = PC Terminal # 9 = Connected to Vo2
- B+5 = PC Terminal # 6 = Connected to Vo1

Finally, it will be necessary to add two additional electrolytic capacitors that lower the noise floor of QPSA-7A for use with the phono stage. These capacitors should be mounted where convenient depending upon your particular situation.



# Audio Research SP-3, A, & A1 Modification Instructions

1. The QPSA-7A will be mounted inside the ARC SP-3 using two of the mounting screws serving to secure the original ARC power supply board. The power supply board is a large printed circuit board measuring approximately 10.5" X 4" running parallel to the rear of the preamp. It contains several large aluminum capacitors (measuring about 1.25" dia. X 3" tall. The QPSA-7A regulator module will be installed using the two screws on the right most edge of the ARC power supply board nearest the right hand side of the preamp (looking from the front). Remove these two screws and placing the component (not foil) side of the QPSA-7A PC board towards the inside of the preamp, reinsert the screws first through the angle bracket, through the original ARC power supply board, and then into the threaded spacer. The foil side of the board should be facing towards the outside of the preamp and the pc board should be within the inside dimension of the preamp body by approximately 1/2".
2. You will now connect the four power supply lines to the associated amplifier power supply points. You will begin with terminal number 6 (B+5) supporting V1 in the phono stage. V1 is located in the three tube row located under the selector switch – V1 is the tube nearest the rear of the preamp. Locate pin 1 and pin 6 of V1 – each will be connected to a 301K ohm power resistor. The other end of both resistors will be terminal number 6. There will be a wire connected to this terminal. You should disconnect this wire. You can choose to simply place electrical tape or heat shrink tubing over the end of this wire or follow it back to its source and cut it and remove it completely. Now connect a new wire (use 22 ga. stranded wire, Teflon insulated) from terminal 6 to terminal Vo1 on QPSA-7A. Near the connection near V1, install a 10uF / 450VDC radial lead electrolytic capacitor so that its positive lead is connected to terminal number 6 and its negative lead is connected to ground.
3. Install a wire (black, 22ga. stranded, Teflon) from a ground point near V1 to the ground connection on QPSA-7. This connection will insure the lowest possible hum and noise performance
4. You will now connect the second power supply line to the second section (V2 & V3) of the phono stage terminal 9 (B+4). Locate V3 – it is the third tube in the three tube row just under the selector switch nearest the front of the preamp. Locate pin 1 & 6 of V3 – they should be connected together. This point is also terminal 9 and once again there should be a wire connected to this terminal that you will disconnect and either insulated or removed as per the previous step. Connect a new wire (22ga. stranded, Teflon) from terminal 9 to terminal Vo2 on the QPSA-7A module. You have now completed the power supply wiring to the phono stage. Near the connection near V3, install a 10uF / 450VDC radial lead

# Audio Research SP-3, A, & A1 Modification Instructions

- electrolytic capacitor so that its positive lead is connected to terminal number 9 and its negative lead is connected to ground.
5. You will now wire the power supply lines to the SP-3 line amplifier. The first stage is amplified by V4. To locate V4, note the five tubes that parallel the front of the preamp. Beginning at the left side (looking from the front) the tube designations are V6, V5, V4, V7 & V8 (V8 will be nearest the phono tubes).
  6. You will now connect the third power supply line from QPSA-7A to the first section of the line amplifier supported by V4 and associated with terminal 20 (B+3). Locate pin 1 and pin 6 of V4 – each will be connected to either a 150K (SP-3) or 301K (later) ohm power resistor. The other end of both resistors will be terminal number 20. There will be a wire connected to this terminal. You should disconnect this wire. You can choose to simply place electrical tape or heat shrink tubing over the end of this wire or follow it back to its source and cut it and remove it completely. Now connect a new wire (use 22 ga. stranded wire, Teflon insulated) from terminal 20 to terminal Vo3 on QPSA-7A. Near the connection near V4, install a 10uF / 450VDC radial lead electrolytic capacitor so that its positive lead is connected to terminal number 20 and its negative lead is connected to ground.
  7. You will now connect the fourth and last power supply line from QPSA-7A to the second section of the line amplifier supported by V5 & V6 and associated with terminal 17 (B+2). Locate pins 1 & 6 of V6 - they should be connected together. This point is also terminal 17 and once again there should be a wire connected to this terminal that you will disconnect and either insulated or removed as discussed previously. Connect a new wire (22ga. stranded, Teflon) from terminal 17 to terminal Vo4 on the QPSA-7A module. Near the connection near V6, install a 10uF / 450VDC radial lead electrolytic capacitor so that its positive lead is connected to terminal number 17 and its negative lead is connected to ground. You have now completed the power supply wiring for the amplifier modules.
  8. The power line outputs of the QPSA-7A have been completely connected to the associated amplifier circuits. Now it is time to connect the input power to the QPSA-7A. As a first step, locate and remove the large metal transistor (Q1, # DTS-410) from the original ARC SP-3 power supply board. This transistor will be mounted to the board with two 4-40 screws / nuts and have a small (2" X 1") heatsink. In addition to the two screws, you will need to desolder the two leads that protrude through the pc board immediately below Q1.
  9. Once Q1 is removed, connect a wire from the collector of Q1 to Vin on the QPSA-7A module. The collector of Q1 is its case and therefore to make the

# Audio Research SP-3, A, & A1 Modification Instructions

connection you will have to solder the other end of the wire to the foil that was captured by the 4-40 nut and star washer originally securing Q1.

10. Connect a black wire to the GND connection of QPSA-7A. Connect the other end of the ground wire to the metal tab of electrolytic capacitor C31 (or C44 on later preamps). C31 (or C44) are large 1.125" dia capacitors that mount to the ARC power supply board via four large metal tabs (there are also one or four other tabs that represent the positive side of the capacitor – ignore these inner tabs).
11. Install a 10uF / 450 VDC radial electrolytic capacitor from QPSA-7A terminal Co to terminal GND.
12. Install another 10uF / 450VDC radial electrolytic capacitor from QPSA-7A terminal Cp to terminal GND.

## D. Final Checkout & Initial Power Application

The ARC SP-3 is delivered with a 1.5 Amp slow blow fuse. Be sure that the correct fuse is installed.

1. Using a digital voltmeter (before power is applied) connect the positive (red) lead to terminal Vin of the QPSA-7 module. Connect the negative lead (black) to ground (make sure you don't use the ARC chassis as the anodized coating may serve to insulate the lead – connect instead to the ground on one row of preamp input / output connectors).
2. Plug in and turn on the preamplifier. Examine the filaments on the six remaining tubes. Observe the voltage reading on your digital voltmeter. Turn off the power if you detect any signs of overheating.
3. Carefully measure the voltage at the four outputs of the QPSA7 – the voltage level should be approximately 400 VDC (+/- 15VDC) but more importantly they should all be nearly the same voltage. Please be careful – these voltages are lethal. If you like you may power down, wait a few minutes and reposition the positive voltmeter lead to obtain the subsequent measurement.

## V. Phono Amplifier Modification

Components are to be inserted on the non foil side and soldered on the foil side. The sequence of assembly has been chosen so that the components with the lowest profile (such as jumpers, low power resistors, IC's etc.) are installed first with higher profile components added until the highest profile components are installed last.

Refer to both our generic SP-3 schematic diagram and the schematic diagram that is found in your owner's manual. We have provided two line amplifiers diagrams depending upon if you have an original SP-3 / SP-3A or an SP-3A1 – please refer to the correct diagram. Be sure to observe correct orientation of polar components (capacitors and diodes). Be sure also to check with an ohmmeter resistor values if you are not absolutely sure of how to read metal film resistor color codes. Note that the part designations are the same for both channels therefore you will be required to identify each part designated twice – once for each channel. We will describe how to locate the part targeted.

1. Locate and remove C1 (39pF Silver Mica). Remember, there are two – one for each channel. The first will be connected to V1 pins 1 & 2. The second will be connected to V1 pins 6 & 7. V1 is part of a group of three tubes located under the selector switch and running parallel to the right side (looking from the front) of the preamp. V1 is the tube nearest the rear of the preamp. You can determine the pin number by counting clockwise from the bottom of the tube (foil side of the board) starting at the gap.
2. Remove C2 (39pF Silver Mica). There are two – one for each channel. The first will be connected to V1, pins 2 & 3. The second will be connected to V1, pins 7 & 8.
3. Locate and replace R2 with a 100 ohm, ½ watt, carbon composition resistor. Remember, there are two – one for each channel. The first will be connected to V1 pin 2. The second will be connected to V1 pin 7. R2 is difficult to access – it may be beneficial to use “solder wick” to remove all the solder before attempting to remove R2.
4. Remove V3. V3 is the tube nearest the selector switch.
5. Locate and remove R9 (301K in early versions and 100K in later versions). R9 can be identified by locating pin 3 of V3 for one channel and pin 8 of V3 for the other channel.
6. Locate and remove C37 (1uF / 100VDC Mylar). C37 can be identified by locating pin 3 of V3 where you will find connected one end of C6 (1uF / 400VDC) – the other end of C6 is connected to C37. Label this point “B” for future reference. Label the other side of C37 “C”. Now remove C37.

To locate the other C37, start with pin 8 of V3 where you will find connected one end of the other C6. On the other side of C6 is connected to the remaining C37. Label this point “B” for this channel and the other side of C37 “C” - again for future reference. Remove the remaining C37.

## Audio Research SP-3, A, & A1 Modification Instructions

7. You had identified C37 (1 uF / 400VDC) in the last step (#6). Replace C37 with a higher quality polypropylene dielectric capacitor (WIMA suggested) of the same capacitance and voltage rating. Repeat for the other channel.
8. Locate V2. V2 is the center tube of the three tubes running parallel to the right side of the preamp. Connect a short insulated wire from pin 1 of V2 to terminal “B” from the previous step. Be sure to keep remain with the same channel – this is not difficult – if you simply imagine a straight line running down the phono section (tubes V1, V2, & V3) one side is one channel and on the other side is the other channel.
9. Connect a short insulated wire from pin 6 of V2 to terminal “B” from step #6. Be sure to use the “B” terminal from the same channel.
10. Connect a short insulated wire from pin 3 of V3 to point labeled “C” from step number 6. Be certain to make the connections within the same channel.
11. Connect a short insulated wire from pin 8 of V3 to point labeled “C” from step number 6. Be certain to make the connections within the same channel.
12. The point that we have labeled “B” in step number 6 above will now have connected to it two of the four RIAA components – a capacitor (C5) and metal film resistor (R10). R10 originally was 100K ohms – change this to 86.6K ohms (1/2 watt, Metal Film). C5 was originally 750 pf silver mica capacitor – change this capacitor to a new value of 887pf. Because 887 pf is not a common value, we will use two capacitors in parallel – a 820pf and a 67pf. One capacitor can be mounted in the original position for C5. The other capacitor should be soldered to the same terminals on the foil side of the printed circuit board.  
Repeat the above for the other channel starting at the other “B” point.
13. The remaining two RIAA components (R7 a 2.2M ohm resistor & C4 a 3000 silver mica capacitor) can be located by following pin 3 of V1 (pin 8 for the other channel). Replace the 2.2Meg ohm resistor with a 1.43 Meg ohm metal film resistor. You should also replace the 3000 silver mica resistor with the same value but with a polystyrene dielectric capacitor.  
Repeat for the other channel starting with pin 8 of V1.
14. Install a 12 Volt 5Watt Zener diode (1N5349) between terminals 10 & 11. Terminals 10 and 11 can be identified by locating pins 4 & 5 of V3. Zener diodes are polar – meaning there is a specific orientation – please observe. Connect the cathode (band) to terminal 10 – connect the other side of the zener diode to terminal 11.
15. Replace R6 (2.21K ohms, metal film) with a 1.3K ohm, ½ Watt, metal film resistor. R6 can be identified by locating pin 3 (and pin 8 for the other channel) of V2. Replace R6 on both channels.
16. Replace C3 (0.1uF / 400 VDC) with a polypropylene dielectric capacitor (WIMA suggested). C3 can be identified by locating pin 2 (and pin 7 for the other channel) of V2.

# Audio Research SP-3, A, & A1 Modification Instructions

17. Visually inspect all of your solder connections. Refer to the adjacent diagram. Quality solder connections should be smooth and shiny. Dull surface or large blobs on the PC board should be cleaned and resoldered. In this case remove the old solder with solder wick or similar and resolder the connection.

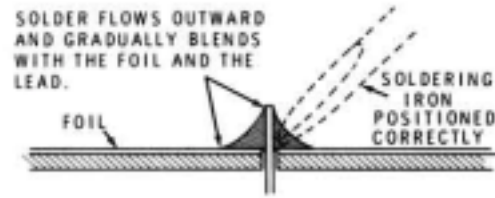

That completes the ARC SP-3 modification.

Replace the cover and enjoy your SP-3 to its full potential.

# Audio Research SP-3, A, & A1 Modification Instructions

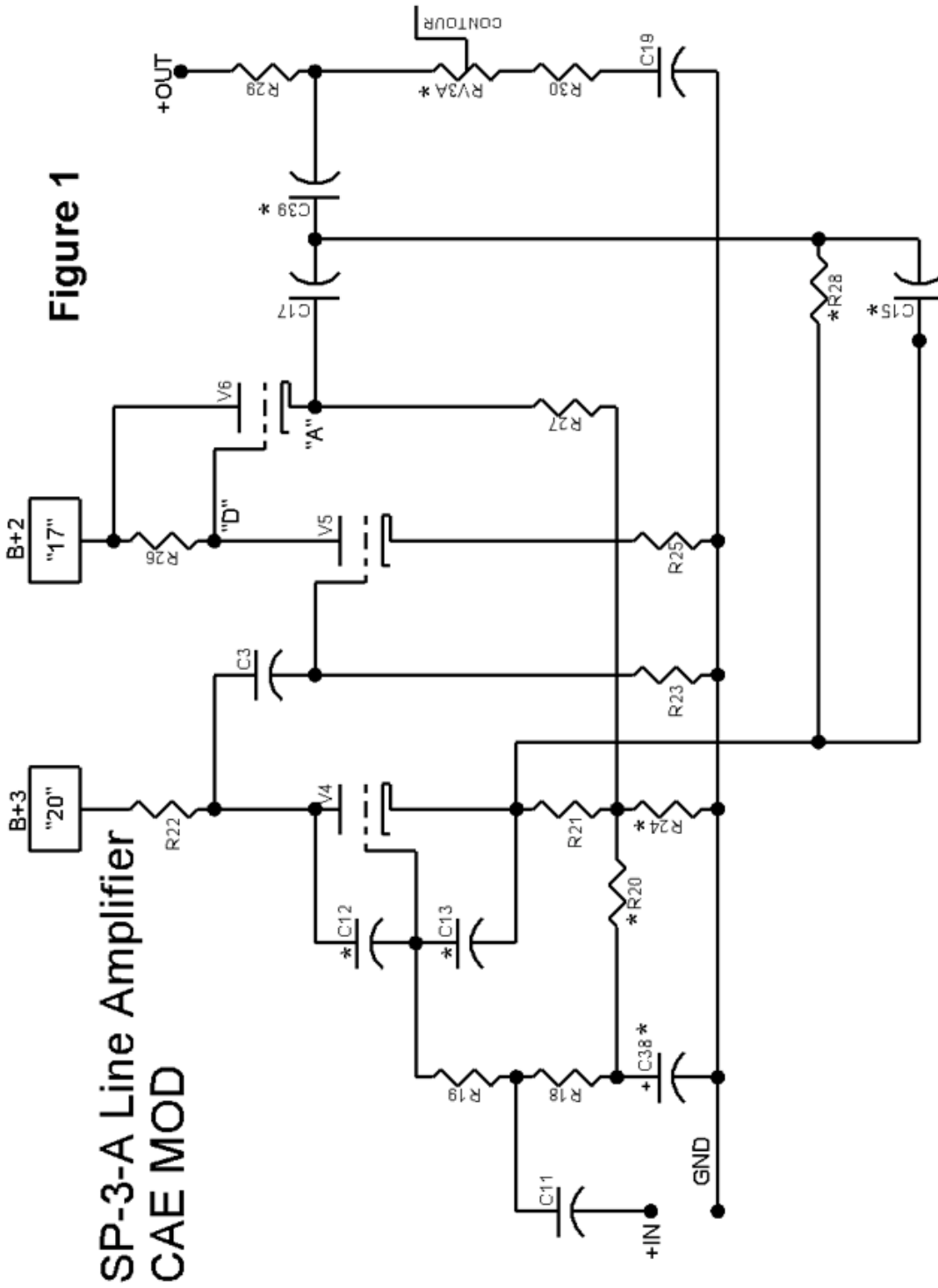

# Audio Research SP-3, A, & A1 Modification Instructions

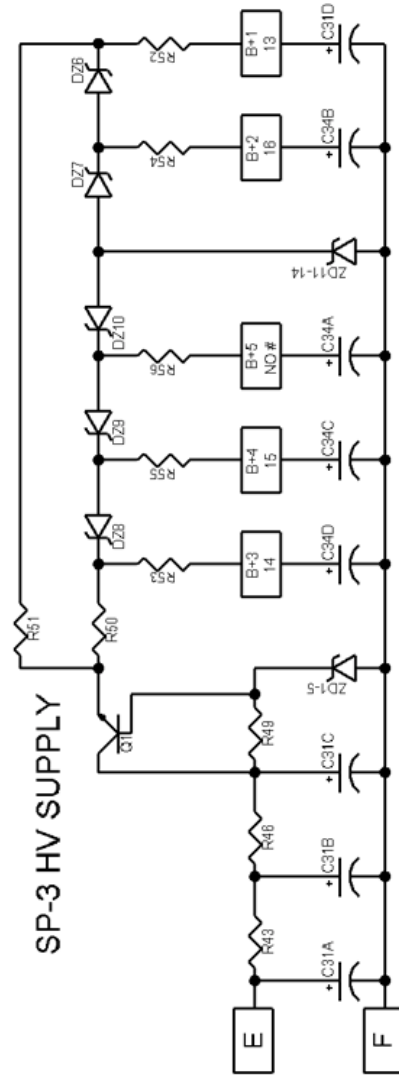
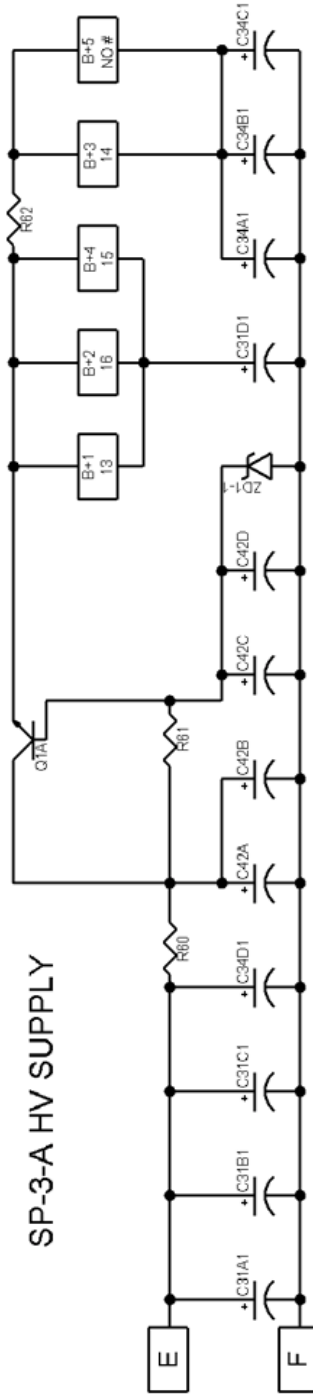
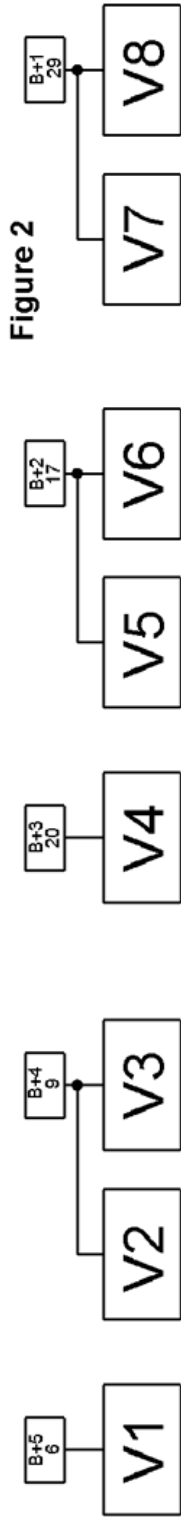



# Audio Research SP-3, A, & A1 Modification Instructions

## CAE QPSA7

Quad Low Impedance Hi-Speed Servo Regulator System

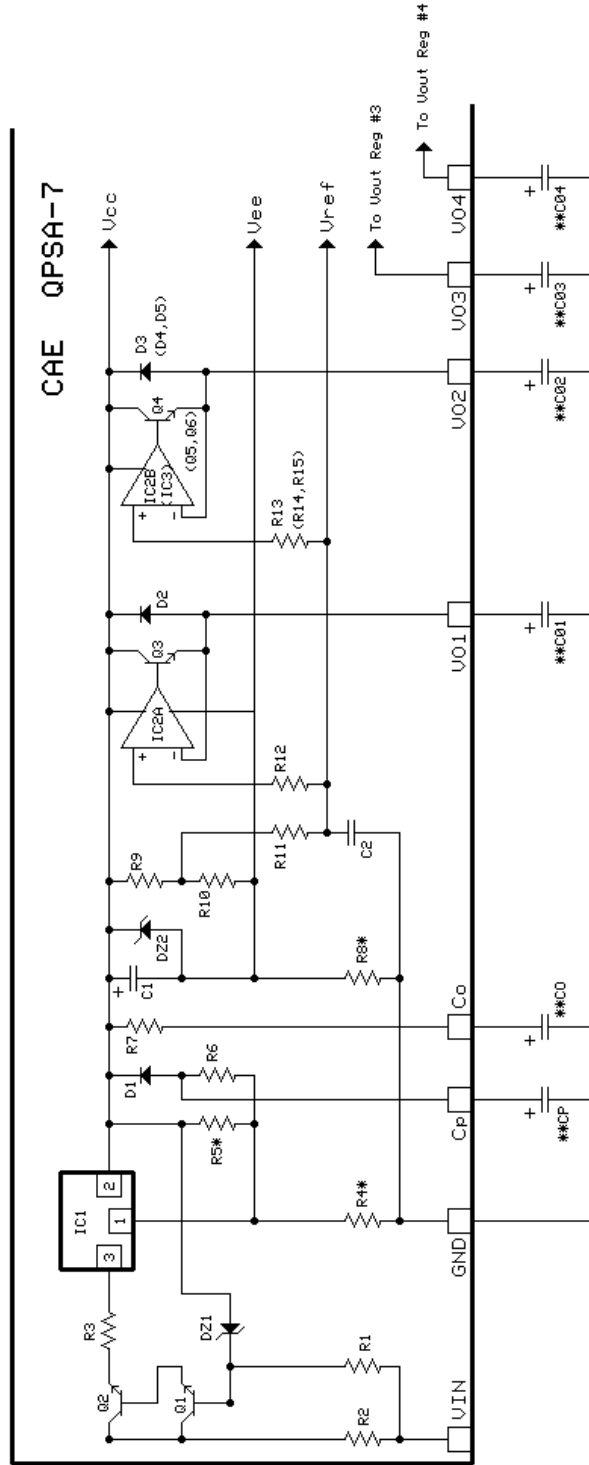

# Audio Research SP-3, A, & A1 Modification Instructions

## CAE QPSA-7A

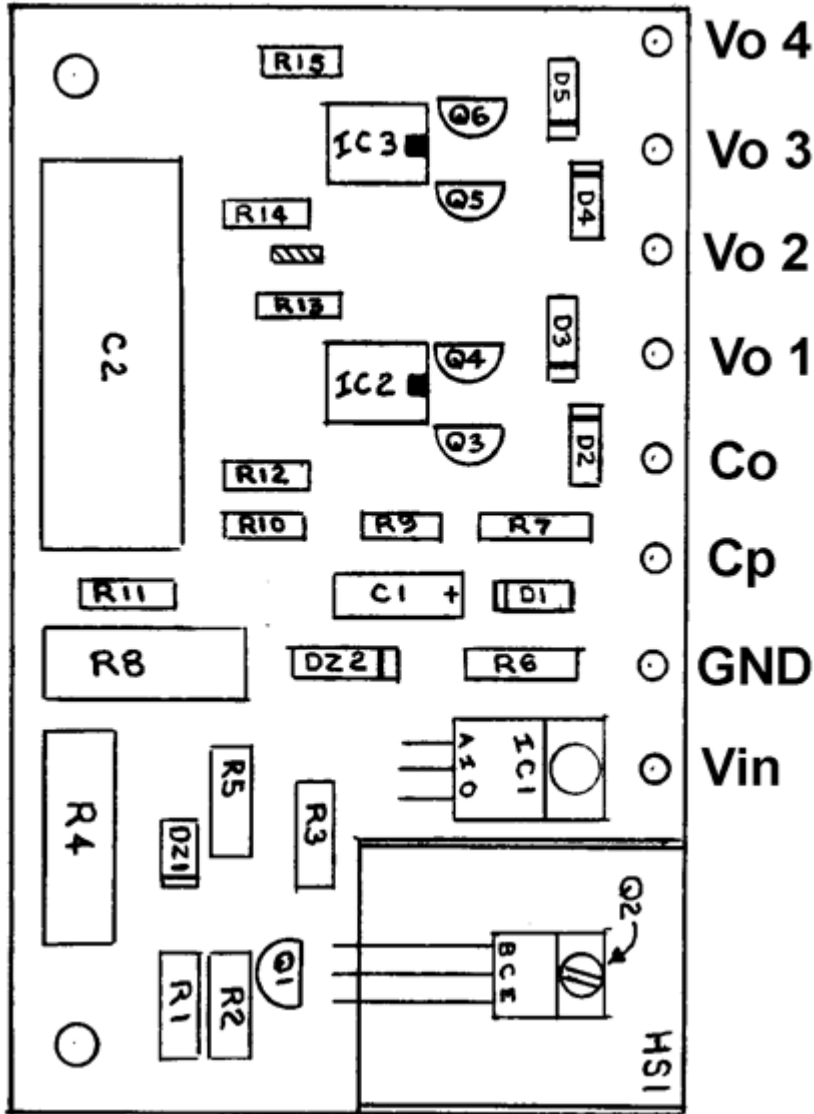

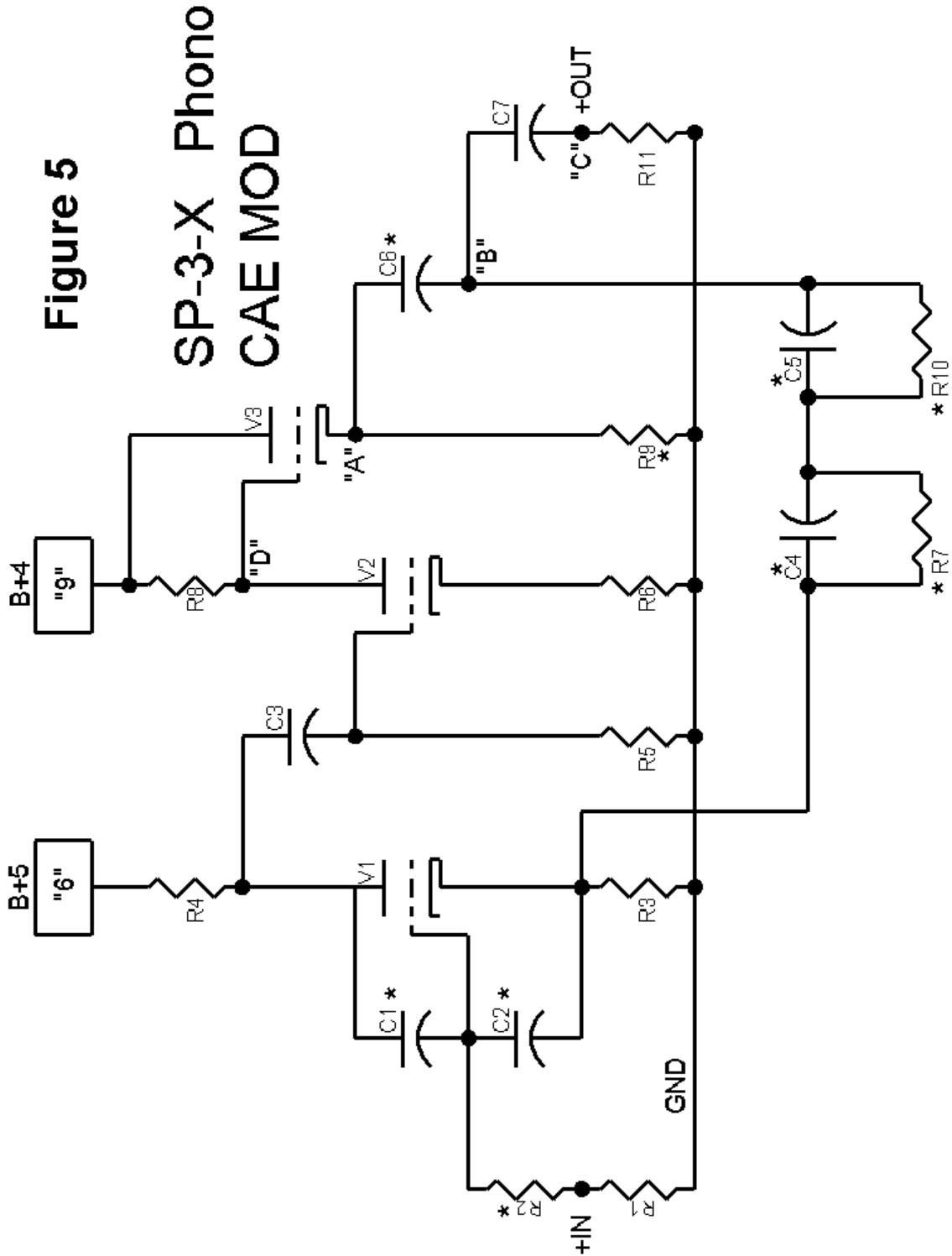



# Audio Research SP-3, A, & A1 Modification Instructions

## CAE ARC SP-3 Modification

12-01 R0

ARC SP-3 Line Amplifier Modification

PAGE 1 of 1

DESIG	DESCRIPTION	QNTY	PART NUMBER	VAL / VOLT
C14	CAPACITOR, POLYPRO (WIMA, MKP)	2	CAE# W1-250	0.1uF/250VDC
C17	CAPACITOR, POLYPRO (WIMA, MKP)	2	CAE# W47-400	0.47uF/400VDC
R24	RESISTOR, METAL FILM	2	MSR#29MF500-4.99K	4.99K OHM, 1/2 W

NOTES: SPA# - Spire Audio part Number CAE# - Curcio Audio Part Number  
 DK# - DigiKey Part Number MSR# - Mouser Part Number  
 SIG# - Signal Transformer Part Number MCM# - MCM Electronics Part Number

## CAE ARC SP-3 Modification

12-01 R0

ARC SP-3 Phono Amplifier Modification

PAGE 1

DESIG	DESCRIPTION	QNTY	PART NUMBER	VAL / VOLT
C3	CAPACITOR, POLYPRO	2	CAE# W1-250	0.1uF/250VDC
C4	CAPACITOR, POLYSTYRENE	2		3000pF
C5a	CAPACITOR, POLYSTYRENE	2	MSR#23PS182	820pF
C5b	CAPACITOR, POLYSTYRENE	2		68pF
C37	CAPACITOR, POLYPRO (WIMA, MKP)	2	CAE# W47-400	0.47uF/400VDC
DZ1	DIODE, ZENER	1	MSR#610-CZ5349B	1N5349B
R2	RESISTOR, CARBON FILM	2	MSR#29SJ250-100	100 OHMS/.25W
R6	RESISTOR, METAL FILM	2	MSR#29MF500-1.3K	1.3K OHMS/.5W
R7	RESISTOR, METAL FILM	2	MSR#29MF500-1.43M	1.43M OHMS/.5W
R10	RESISTOR, METAL FILM	2	MSR#29MF500-86.6K	86.6K OHMS/.5W

NOTES: SPA# - Spire Audio part Number CAE# - Curcio Audio Part Number  
 DK# - DigiKey Part Number MSR# - Mouser Part Number  
 SIG# - Signal Transformer Part Number MCM# - MCM Electronics Part Number

## CAE Model QPSA7

11-01 R2

QPSA7 Preampifier Quad Hi-Speed Servo Regulator Module

PAGE 1

DESIG	DESCRIPTION	QNTY	PART NUMBER	VAL / VOLT
C1	CAPACITOR, ELECTROLYTIC (Axial)	1	MSR# 140-XAL25V10	10uF / 25 VDC
C2	CAPACITOR, MYLAR or POLYPRO	4		0.47uF/400VDC
Cp & Co	CAPACITOR, ELECTROLYTIC (RADIAL)	1	MSR#140-XRL-450V10	10uF/450VDC
C01 thru Co4	CAPACITOR, ELECTROLYTIC (RADIAL)	1	MSR#140-XRL-450V10	10uF/450VDC
D1 thru D5	DIODE, POWER	5	MSR#583-1N4007	1000 V / 1A
DZ1	DIODE, ZENER	1	MSR#583-1N4735A	6.2V / 0.5 W
DZ2	DIODE, ZENER	1	MSR#583-1N4751A	30V / 0.5 W
HS1	HEATSINK, TO-220	1	MSR#-532-530613B00	TO-220
IC1	REGULATOR, ADJ	1	MSR#511-LM317T	LM-317T
IC2 & IC3 (Std)	OPERATIONAL AMPLIFIER, DUAL	2	MSR#511-LF353N	
IC2 & IC3 (Opt)			CAE OPA-2R	
Q1	TRANSISTOR, NPN HI VOLTAGE TRANSISTOR, NPN HI VOLTAGE POWER	1	MSR# 610-MPSA42	MPS-A42
Q2	TRANSISTOR, NPN	1	MSR# 511-TIP50	TIP-50
Q3, Q4, Q5, Q6	TRANSISTOR, NPN	4	MSR#512-2N4401	2N4401
R1	RESISTOR, CARBON FILM	1	MSR#29SJ500-47K	47K OHMS- 0.5 W
R2	RESISTOR, CARBON FILM	1	MSR#29SJ500-47K	47 OHMS- 0.5 W
R3	RESISTOR, CARBON FILM	1	MSR#29SJ500-33	33 OHMS- 0.5 W
R4	RESISTOR, MET OXIDE	1	DK#P100KW-3BK-ND	100K, 3W
R5	RESISTOR, CARBON FILM	1	MSR#29SJ500-332	332 OHMS- 0.5 W
R6	RESISTOR, CARBON FILM	1	MSR#29SJ500-100	100 OHMS- 0.5 W
R7	RESISTOR, CARBON FILM	1	MSR#29SJ250-4.7	4.7 OHMS- 0.5 W
R8	RESISTOR, MET OXIDE	1	DK#P47KW-3BK-ND	47K, 3W
R9, R10	RESISTOR, CARBON FILM	2	MSR#29SJ250-10K	10K OHMS- 0.25 W
R11	RESISTOR, CARBON FILM	1	MSR#29SJ250-3.3M	3.3M OHMS- 0.25 W
R12, R13, R14, R15	RESISTOR, CARBON FILM	4	MSR#29SJ250-10K	10K OHMS- 0.25 W
X1	PRINTED WIRING BOARD	1	CAE # PWB-PC-7A	
X2	BRACKET, 90 DEG, 6-32	2	CAE # BRACKET-90	

NOTES:

SPA# - Spire Audio part Number      CAE# - Curcio Audio Part Number  
 DK# - DigiKey Part Number      MSR# - Mouser Part Number  
 SIG# - Signal Transformer Part Number      MCM# - MCM Electronics Part Number